

Energy Saving Module

(HG-ESM-01)



Leading Company of Advanced Sensors

HAGISONIC Co., Ltd.

Sensors & Application Systems for Robots, AGVs, Automobiles, Automations
and Energy-Saving Apparatus



Hagisonic Co., Ltd.

www.hagisonic.com / hagisonic@hagisonic.com

Tel : +82-42-936-7740 / Fax : +82-42-936-7742

Energy Saving Module

■ Model : HG-ESM-01

■ Product overview

- Complementary operation module between human sense infrared sensor and ultrasonic sensor
- Features a wide range of modes of control, including frequent adjustment
- Indirect discrimination of the human body and the object
- Smooth control with dimming function
- Interworking and self-adjusting of exterior lighting
- Get the latest high-performance dedicated chip (ASIC)
- Small scale low power design
- Consideration of aesthetics as a embedded ceiling and wall in a building

■ Features

- Automatic sensitivity adjustment, combined with two sensors : PIR and ultrasonic., addresses problems with traditional sensor lights.
- Selection and adjustment of various operating modes (Sensor Auto/Manual, Interworking of exterior illumination, Dimming ability availability, Use and adjust residual lighting, Duration control, etc.).
- No one from the office toilet or other is moved and suddenly lights out while seated.
- Auto Dimming, fade out slowly, eliminates confusion caused by sudden lights off.
- Determine the situation when non-human luggage is accumulated and turn off automatically after a certain time.
- Compact module with an external diameter of 70mm (Diameter of landfill 55mm) and easy to install without compromising the aesthetics.
- No need for a separate power source, form that utilizes part of the existing LED light source.

■ Applications

- LED Special Lighting
- Underground Parking Lot Lighting Control
- Security, such as detection of intruders
- Other aisles, stairs, office, study room, (public) bathroom, logistics warehouse, etc.

Energy Saving Module

■ Model : HG-ESM-01

▣ Internal PCB configuration

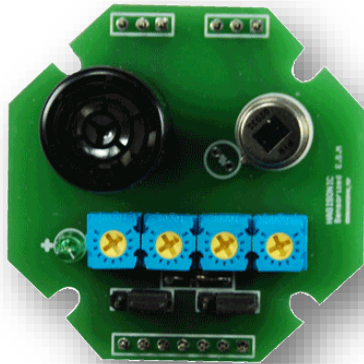

(Front)

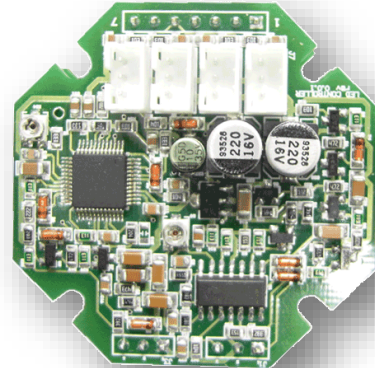

(Back)

< If you want to purchase in a modular format without a case, ask for additional information. >

▣ How to Install

- The power supply units are models supported by the power supply required by this module (10V to 15V). Dimming is possible when the analog control input function is available. It is also applicable to lighting or other electrical appliances with a Power Pack (or Switch Pack). (In this case, the function of the switch is simple)
- Drill holes in suitable locations, such as the ceiling and walls.
- Connect the power supply unit (SMPS) and the energy mains attached to the main body of the illuminating lamp with a connector cable. (Use a three-ply float cable or stereo cable as the cable is suitable, and it can be a little long.)
- Insert the main object into the hole. As the spring arm is constructed, it can be installed conveniently without tightening screws.

▣ Check operation and prepare for adjustment

- When the light switch is inserted, it turns on, and the circuit is stabilized at the first turn on, and then the circuit is turned off. If the person continues to move near the sensor, turn off the lights, and do not move the sensor for a while.
- When the lamp is turned off, the lamp turns on when it is approached again. If the lamp stops moving, or if it leaves the seat, the lamp turns off again. (In this case, as Temporary Mode, the situation is when a person passes by briefly, and it goes out after approx. 10-20 seconds)

Energy Saving Module

■ Model : HG-ESM-01

▣ How to explain and adjust each part

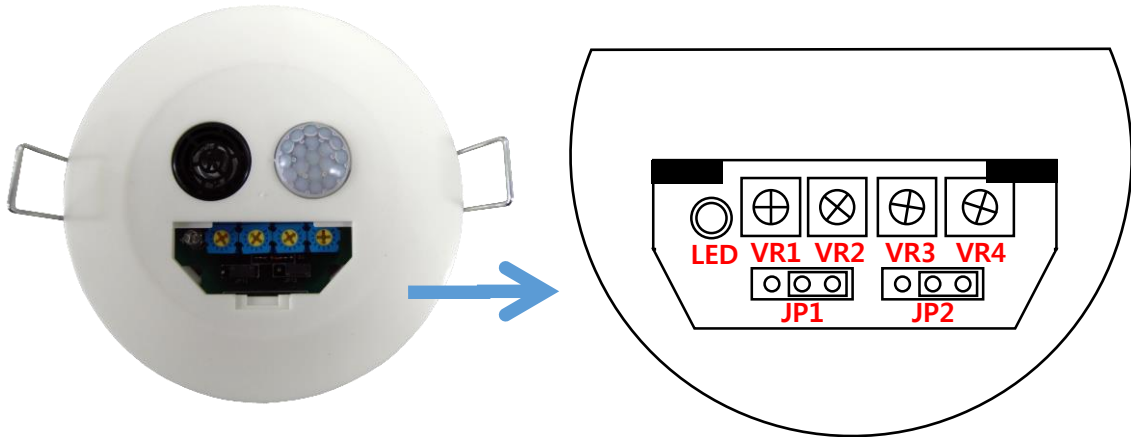

1) LED Indicator : When the ultrasound detects an object, it blinks. It is seen as brighter and brighter from the detection limit distance.

- ① Slowly turning VR 1 clockwise will cause the LED to blink at a point.
- ② Keep away from adjustment operators ' hands or heads, as they can detect them, and observe whether or not LEDs still flash.
- ③ When the detection is lost, turn it slowly clockwise to expand the detection area.
- ④ Repeat this operation to locate the point at which the detection begins consistently on the floor face or wall other fixed objects other than the operator's body.
- ⑤ These methods can be a little uncomfortable and, therefore, a masking plate would be convenient because it would avoid reflection on the operator's hand.
- ⑥ Turn VR 1 slightly counterclockwise to set it in the state immediately before detecting the fixture.
- ⑦ It is necessary to observe closely (if not already detected) and keep a small amount of secure objects at a distance from the detection area boundary as the object is less prone to LED flashing and may gradually become brighter as it approaches.
- ⑧ Check the adjustment after adjustment and modify it slightly, as there is a concern about malfunction (always recognized as Steady Mode).
- ⑨ In this state, access to persons or other objects and when the LED is flashing again is complete.

Caution : for heavy sound absorbing clothing, etc., flickering may be unstable (intermittent detection) within the distance range, but it is also recognized as Steady Mode and works normally.

Energy Saving Module

■ Model : HG-ESM-01

▣ How to explain and adjust each part(Cont.)

2) Ultrasonic range(VR1) : Rotate clockwise to extend the detection distance area.
(Location of no reduction minimum when shipped from the factory)

- ① It is advisable to adjust VR 2 to the desired intensity of lighting during the non-lighting time periods, such as early morning or late afternoon. (Turn it counterclockwise and it will be dark)
- ② If the PIR sensor lens is covered, check that the lighting is significantly brighter.
- ③ Check whether the normal use conditions provide sufficient brightness at night.
- ④ If the sensor is covered up or brighter, it is too restricted, so turn VR 2 more clockwise.
- ⑤ In this case, the influence of many of the lights on the surrounding area may be a little bit below Full Power, but you can use it as intended without any problems.
- ⑥ This adjustment needs to be repeated several times over several time periods until satisfactory.

3) Association with outside luminance(VR2) : Adjust the brightness to the desired level in bright spots, such as windows, by automatically adjusting the lighting to be weaker. (Rotate clockwise to gradually increase the intensity, and when shipped, it is in its maximum position)

- ① Once turned on, cover the lens of the PIR sensor with opaque tape, and wait for it to extinguish, for additional detection to occur.
- ② For fast turning off, evacuate the ultrasonic detection range and leave it in the Temperature mode.
- ③ In this case, the lights are switched off within a maximum of 20 seconds.
- ④ Turn VR 3 to the left and right to adjust the desired luminance.
- ⑤ The remaining illumination is brighter in the clockwise direction. As the maximum point is the remaining full power, automatic lights can not be turned off, as if the sensor lights were not used in effect. (Manual Mode)
- ⑥ Counterclockwise end is completely off, since there is no residual illumination.
- ⑦ It is advisable to make this adjustment at night, and during the day (strong external illumination) it is difficult to verify and to adjust the desired illumination with a light-intervient function. If adjustment is inevitably required during the day, this interlock function is disengaged (JP 1 removal).
- ⑧ When the adjustment is complete, remove the tape, etc. that covers the PIR sensors.

CAUTION : Even though the lens is hidden, it can be detected in rapid motion and turned on again, so approach it as slowly as possible.

Energy Saving Module

■ Model : HG-ESM-01

▣ How to explain and adjust each part(Cont.)

- 4) Residual quantity of light(VR3) :** A feature that applies to areas where complete lights are not available, such as underground parking lots, and requires light levels after switching off. It is controlled when the clock direction increases, and the lowest mode is always switched off (When shipped from the factory, all lights out)
- ① This adjustment time setting is the duration of continuous illumination and shift detection in Steady Mode, which is approximately 5 minutes or less.
 - ② Normally, it takes about 2-3 minutes to get it right, so it is okay to set VR 4 to approximately medium. (As in factory setting)
 - ③ If a shift is detected even once within the time set, the duration is extended by the new set time from that point.
 - ④ For objects or inactive humans (e.g. while asleep), the lights off automatically after a set time has elapsed without movement.
 - ⑤ If a person or object disappears from the area (undetected by ultrasonic waves), it is immediately returned to the Temporary Mode and turned off within a maximum of 20 seconds.
 - ⑥ The duration of illumination can be extended as a special order specification.
- 5) Lighting hour(VR4) :** Adjust the duration of the Steady Mode (if a person or object is inside the station). Turn it clockwise to extend the time and set it up to about five minutes. (intermediate location when shipped from the factory)
- ① Remove the Jumper Pin (TP1) of the figure when the device is ready for use when shipped from the factory and is not in use. (To prevent the pin from being lost, plug it in the left side.)
 - ② If not available, it shall be set at the maximum brightness when lit.
- 6) Association with outside luminance(JP1) :** If you remove the Jumper Pin, it is turned on with the maximum brightness regardless of the outside illumination. (To prevent the Pin from being lost, it is connected to the right as the function use mode when shipped from the factory.) In addition, setting VR 2 to its maximum also has the same effect.
- ① Remove the Jumper Pin (JP 2) from the figure to the left, if it is scheduled to be used on the factory floor and is not to be used immediately (Cut off immediately).
 - ② In the Dimming Off state, Fade Out is slowly performed over 6 to 7 seconds.
 - ③ When Cut Off, the power is turned off swiftly within 0.5 seconds.
 - ④ Dimming Off Time can be extended by more than a few seconds by order.
- 7) Light-off mode(JP2) :** Cut Off is also set when the pin is removed when the lamp is turned off. If the pin is not installed in the factory, it should be installed in the useable mode.

Energy Saving Module

■ Model : HG-ESM-01

■ Quick adjustment order at the beginning of installation

- The adjustments described so far are for each function and are not in the order of adjustment. Therefore, it is recommended to adjust the instrument in the following order. (Ultrasonic waves start in non-functional state.)
 - ① If the basic operation is checked immediately after installation, the interlock function (VR 2) with ambient light while it is turned on again. As explained earlier, the time frame is not clear. (Leave in maximum factory position if not required or remove TP1)
 - ② Adjust the residual ore (VR 3) while preventing re-lighting with opaque tape. (If not required, leave it in the factory position as minimum)
 - ③ Remove the tape and adjust the ultrasonic distance (VR 1) while it is lit. (The structure is ultrasonic wave fired only in the ON state. In this case, it is convenient to use a simple cover plate.)
 - ④ Adjust the duration of lighting (VR 4) to the current state (shipped state) and adjust it frequently.

■ Special skill

- Temperature mode is also available in two cases, when a person has temporarily walked past a sensor (corridor, passage, etc.) and has taken several actions around the sensor and left immediately.
- In the case of the electronic device, the detection is performed only once or twice and the duration is short, so it is switched off immediately after 10 seconds.
- In the latter case, if detected three to four times more, the duration is added and the lights off in about 20 seconds.
- Therefore, depending on the time of person's stay or action, the lighting time can be adjusted to maximize convenience and power-saving effects.
- In the Temporary Mode, if sufficient activity is detected continuously within the duration (20 seconds), it can be kept turned on and operated like Steady Mode. (In this case, the movement should be slightly larger)

■ Glossary

- Temporary Mode : A PIR sensor is detected and illuminated with somewhat faster human motion, and has not yet entered the detection area of the ultrasonic sensors. The sensitivity of the movement is at normal levels and the duration (lights up in 20 seconds), and
- Steady Mode : Ultrasonic sensor detection status immediately after the Temporary mode, during which the body enters and is present in that area, transitions to high speed, detection of movement, and sets the duration (20 seconds to 5 minutes) significantly.

Energy Saving Module

■ Model : HG-ESM-01

▣ Timing Chart

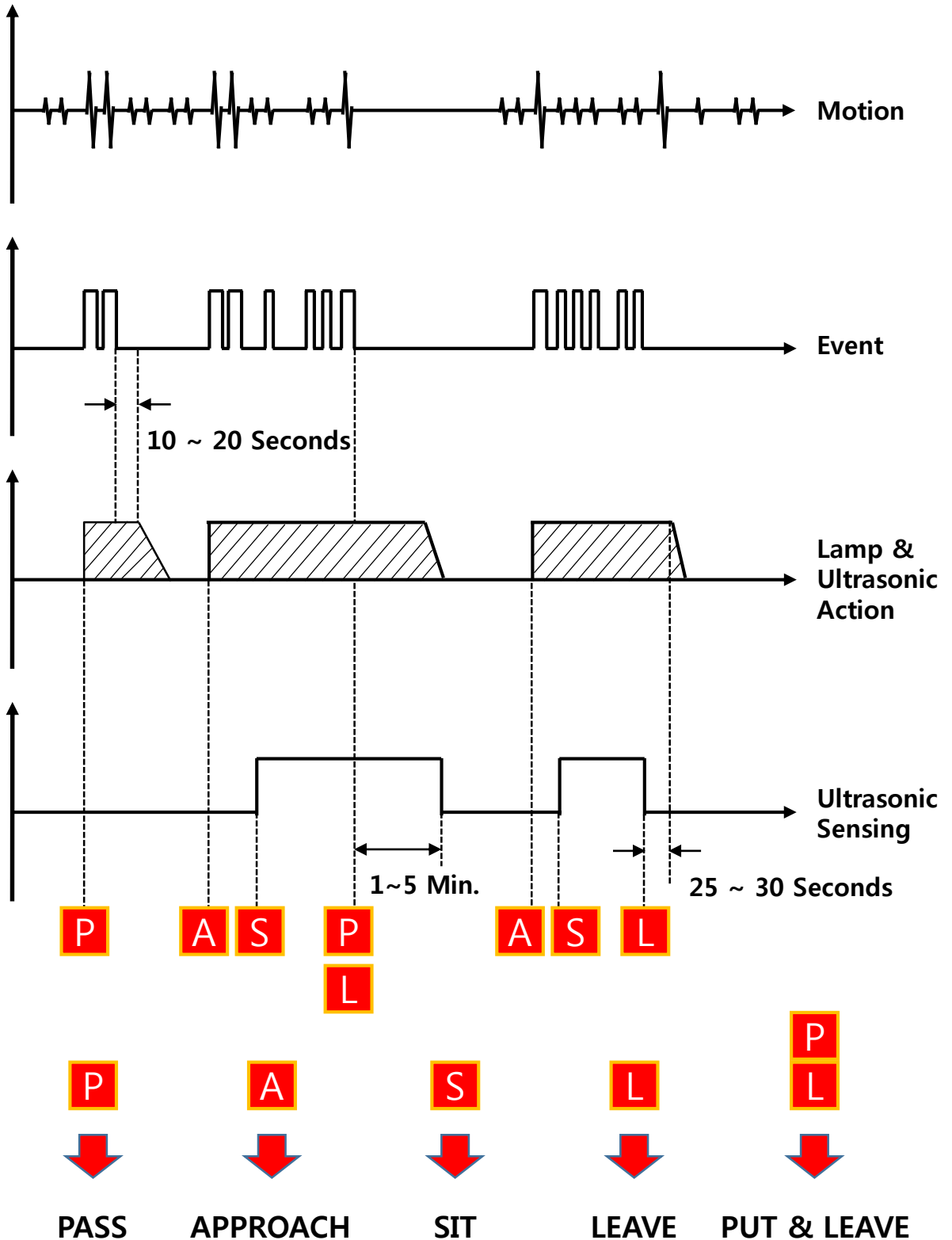

Energy Saving Module

■ Model : HG-ESM-01

▣ Product installation distance example

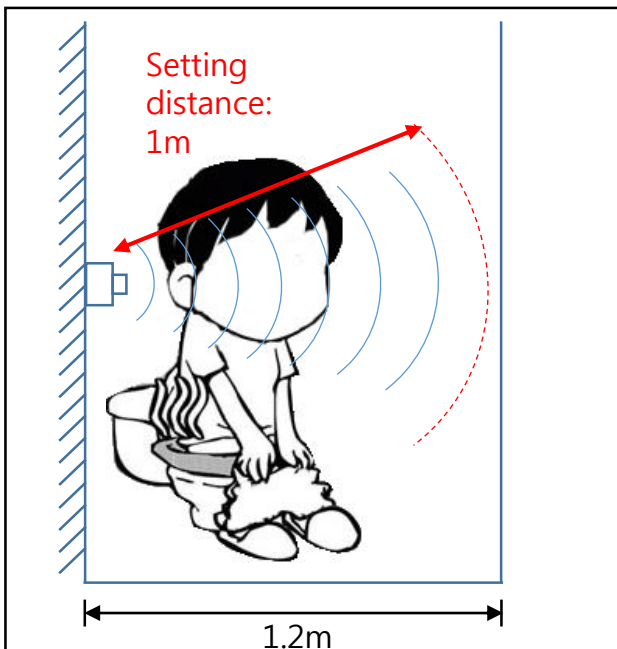
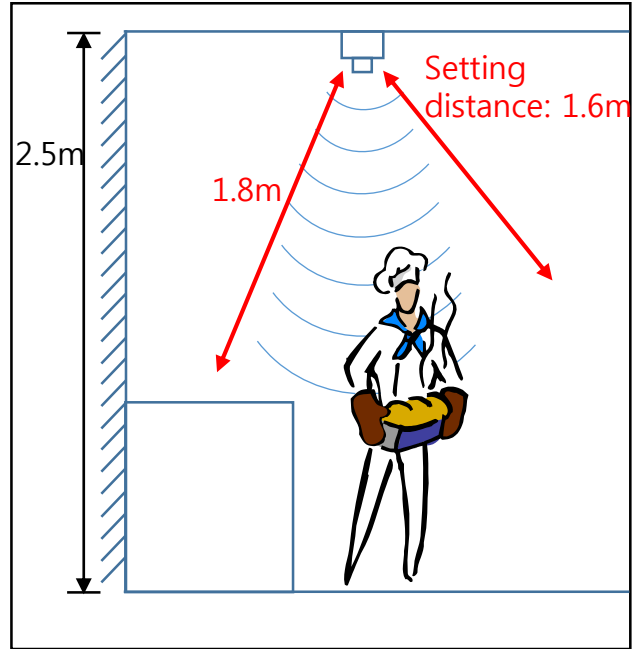
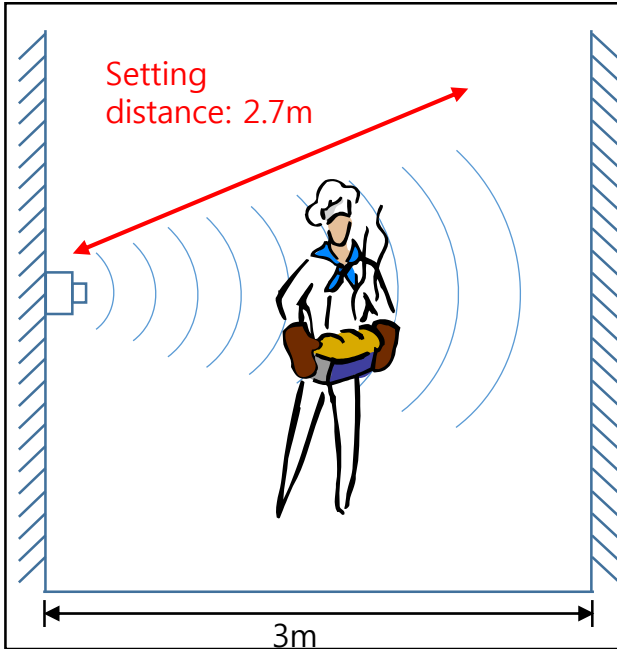

Energy Saving Module

■ Model : HG-ESM-01

▣ Example Product Configuration

- (public) restroom, underground parking lot, warehouses and etc.

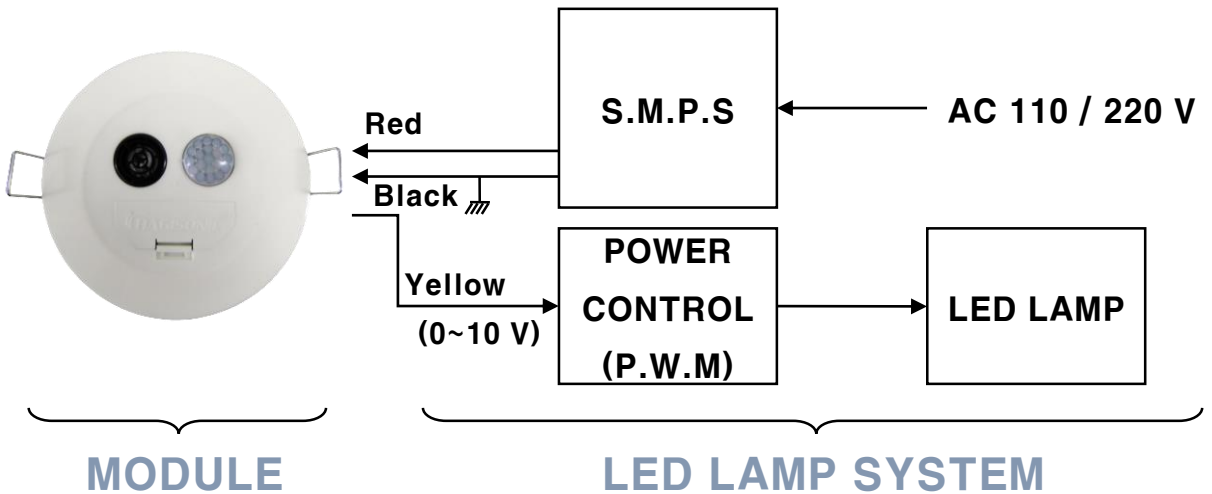

- Electricity control of an electric fan, air-conditioner and other home appliances. (A-1)
- Stand-by power control of computer (monitor), TV and etc. (A-1)
- Security and surveillance applications such as intruder detection etc. (A-2)

